



Accessories and Options

- › BIB Rack
- › Chiller

Certified by these agencies:



CUSTOMER SERVICE

Should you require more information about our products, please do not hesitate to contact our customer service team at custserv@lancerworldwide.com.

Touchscreen Tower (TST),

the award-winning TST offers customers a personalized and unique dispensing experience. With just the touch of a button your customers can choose from a variety of beverage choices including trending specialty beverages like energy drinks and better for you drinks.

Features

- › Unique beverage offerings
- › Carbonated or non-carbonated
- › Dispense up to 10 brands and up to 4 bonus flavor shots
- › Interactive touchscreen provides a personalized experience
- › Adjustable interface and lighting patterns
- › Small footprint
 - 9.4" (238.76 mm) x 18.7" (474.98 mm)
- › Countertop installation
- › Aether tea cartridge included



WARRANTY

For warranty specifics by product, contact your Lancer™ Sales Representative. Equipment design and/or specifications are subject to change without notice.

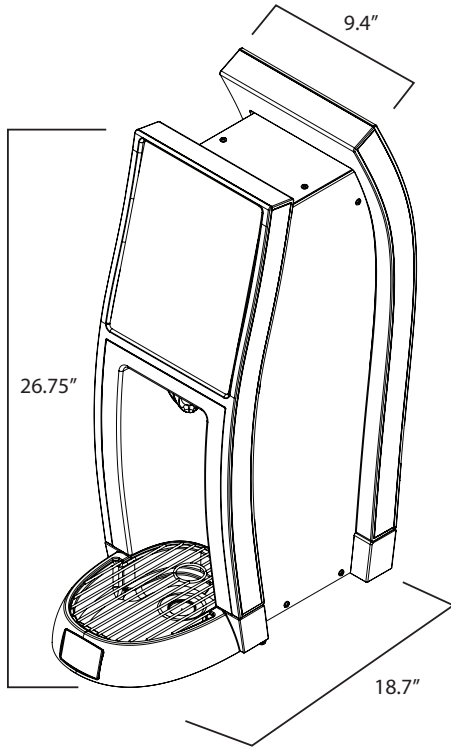

Distinctive Design

- › 6 Brands - Up to 4 bonus flavors optional
- › 8 Brands - Up to 2 bonus flavors optional
- › 10 Brands - No bonus flavor options

Dimensions

Height: 26.75" (679.45 mm)

Width: 9.4" (238.76 mm)

Depth including drip tray: 18.7" (474.98 mm)

Weight

Shipping: 35lbs (15.88 kg)

Electrical

2 Amp, 24V, 50/60hz

For more information visit lancerworldwide.com or call 1-800-729-1500

6655 Lancer Boulevard • San Antonio, TX 78219 • 210-310-7000 • Fax: 210-310-7250 • © 2024 Lancer™ Worldwide • TST 02/25

"Lancer" and "Lancer Worldwide" are trademarks of Lancer Corp. © 2024 by Lancer™, all rights reserved.